

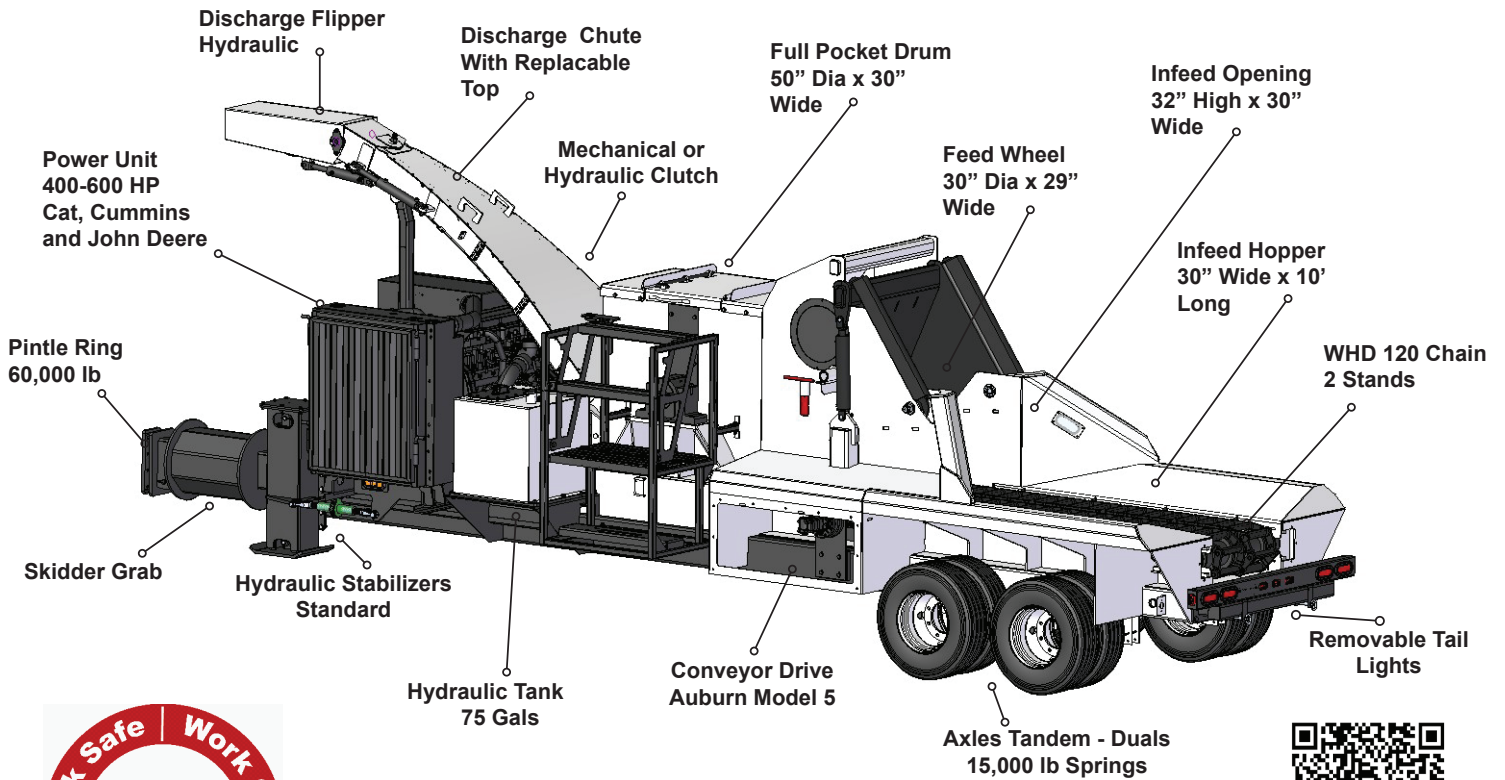

TEREX®

ENVIRONMENTAL EQUIPMENT

TECHNICAL SPECIFICATIONS



TBC430

TBC 430

Biomass Whole Tree Chipper Specifications

Engineered and constructed for forestry and land clearing applications.

SPECIFICATIONS

Operating Weight	38,000 lbs
Engine Options	
Caterpillar	440 hp
Cummins	400-500 hp
John Deere	500 hp

FEATURES

Drum Size	50" Diameter x 30" Wide
Infeed Opening	32" High x 30" Wide
Feed Control	Remote with Autofeed
Cutting System	Full Knife Pocket

DIMENSIONS

Width	8' 10"
Height	11' 0"
Length	31' 10"

Engine/Drive

- ▶ Make / Model: CAT, Cummins, John Deere
- ▶ Hp: 400-500 hp
- ▶ Fuel: Diesel
- ▶ Fuel Tank Capacity (gl): 168 gallons
- ▶ Oil Capacity (qt): 60
- ▶ Cooling Medium: Air
- ▶ Cylinders: 6
- ▶ Drive: Disc Clutch with Belts

Cutting System

- ▶ Drum Size: 50" Dia. x 30" Width
- ▶ Drum Speed rpm: 700 rpm
- ▶ Knives: (6) Adjustable Knives
- ▶ Anvil: 4 edges, 3/4" Steel

Feed System

- ▶ Infeed Opening: 32" High x 30" Wide
- ▶ Feed Table Height: 44"
- ▶ Feed Table Length: 120"
- ▶ Feed Wheel Diameter: 30"
- ▶ Feed Wheel Length: 29"
- ▶ Feed Rate (fpm): 120
- ▶ Motor Displacement (cu. in.): 6.5 cu. in.
- ▶ Feed Control: Remote with Auto Feed

Discharge System

- ▶ Discharge Height: 11' 0"
- ▶ Chute Rotation: 90°
- ▶ Rotation Type: Hydraulic

Chassis

- ▶ Frame: Tube
- ▶ Hitch Type: 5th Wheel
- ▶ Tool Box: Option
- ▶ Wheels: Tandem Duals
- ▶ Tires: 23.5 / 75R 17.5
- ▶ Axle: (2) 15,000 lb. spring axle

Hydraulic

- ▶ System: Open Center / Pressure Compensated
- ▶ Hydraulic Tank Capacity (gl): 75
- ▶ Filtration: 10 Micron Return / 150 Micron Suction
- ▶ Pump - Direct Drive (gpm): (2) 27 gpm
- ▶ System Relief (psi): 2,500
- ▶ Hydraulic Connections: O-Ring / O-Ring Face Seal

Electrical

- ▶ System Voltage: 24V
- ▶ Battery: (2) 12V 1,400 CCA
- ▶ Trailer Plug Connections: 7-Pole
- ▶ Lights: Turning, license, brake, tail and side marker.

Weights

- ▶ Operating Weight (lbs): 38,000 lbs.

Dimensions

- ▶ Width: 8' 10"
- ▶ Height: 11' 0"
- ▶ Length: 31' 10"

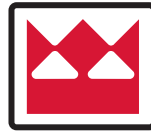

TEREX®

TBC 430

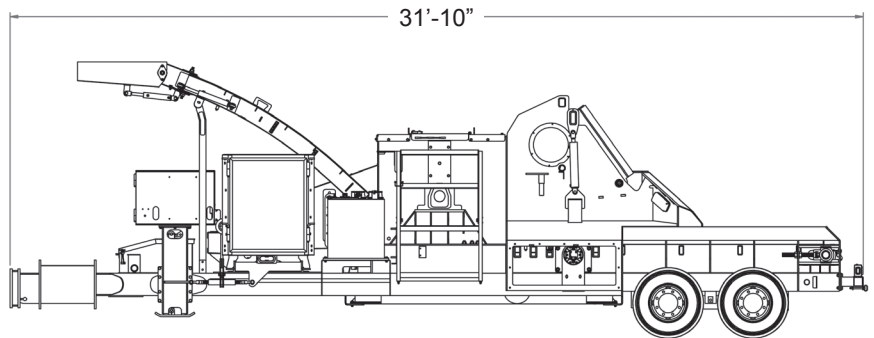
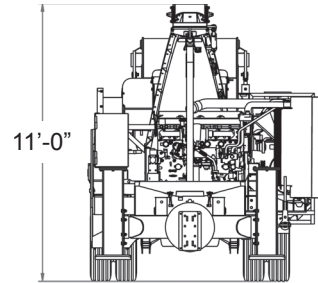
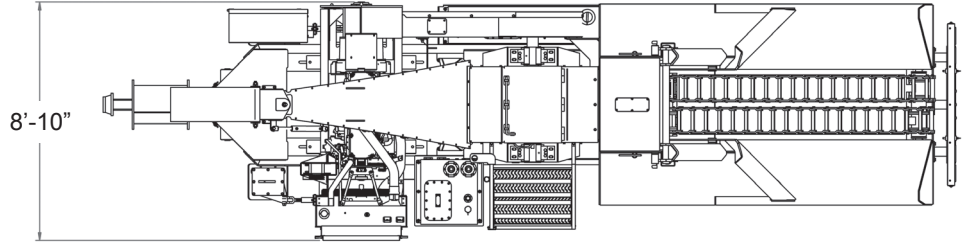

www.terex.com/environmental-equipment

Product specifications and prices are subject to change without notice or obligation. The photographs and/or drawings in this document are for illustrative purposes only. Refer to the appropriate Operator's Manual for instructions on the proper use of this equipment. Failure to follow the appropriate Operator's Manual when using our equipment or to otherwise act irresponsibly may result in serious injury or death. The only warranty applicable to our equipment is the standard written warranty applicable to the particular product and sale and Terex makes no other warranty, express or implied. Products and services listed may be trademarks, service marks or trade-names of Terex Corporation and/or its subsidiaries in the USA and other countries. All rights are reserved. Terex is a registered trademark of Terex Corporation in the USA and many other countries.